

# The Leading Edge



Quarterly News from Miller Edge, Inc.

Summer 2023



## End User Solution: Levels of Protection Guide

Easily Identify Risks & Safeguarding Solutions for Commercial Overhead Doors

The level of protection required for a safe motorized commercial overhead door can vary vastly. With all the available options for entrapment and hazard zone protection, determining and understanding the best safety device for the job might seem overwhelming for end users.

Our new Levels of Protection guide leads end users through assessing the risks for their distinct environments and aiding them in identifying and selecting the most suitable safeguarding solutions for their motorized commercial overhead doors.

From hazard and risk awareness to cost considerations and other factors, the guide walks end users through the

risk evaluation process to identifying the right protection strategy.

The guide simplifies the process of choosing the type and level of safety needed by zeroing in on the key features and advantages of the available contact and non-contact product options.

With this guide, equip your customers to make well-informed choices tailored to their unique needs using this comprehensive guide.

**DOWNLOAD  
THE GUIDE**

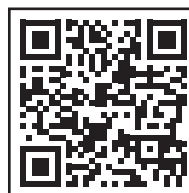

## CONTENTS

Levels of Protection .....	1
ANSI/CAN/UL 325: 2020 .....	2
Product Spotlight .....	2
Industry Updates .....	3
New Products .....	3
Miller Edge Updates .....	4
Events.....	4
Architect's Corner .....	5
Dealer Spotlight .....	5
Talk to the Tech.....	6
Levels of Protection Guide...Insert	

## FEATURE

### Live Webinar: ANSI/CAN/UL 325: 2020

Miller Edge recently hosted a live webinar addressing ANSI/CAN/UL 325: 2020, the new safety Standard in Canada, which went into effect on February 28, 2023 and supersedes CSA C22.2 No. 247:14, the legacy standard in Canada regulating the requirements for doors, gates, and other such assemblies that include electrically powered opening and closing appliances.

Attendees learned about the Standard's history and regulatory landscape from David Makepeace, General Sales Manager at Miller Edge; Amancio Sanchez, International Sales Manager: Americas at Miller Edge; and Steve Kuscsik, Principal Engineer at UL Solutions. Webinar attendees also gained valuable insights into

how the new Standard can effectively contribute to business growth.

While discussing what the change in Standard means to door and gate professionals working in Canada, Steve Kuscsik shared, "dealers, installers, and service personnel are the most important element in this industry. Standards and codes lay out regulations, manufacturers produce the product, but it's up to you to choose the right product for the job, to install it properly, and to service it properly. To me, that's what matters most." He then proposed, "take this messaging out to your customers and explain to them why you are installing a specific product, why you are installing it at a certain height, why this gate operator needs an edge sensor and a photo

eye in this zone, and you can explain with confidence that you are doing the job properly to meet established safety requirements, not only for your company's safety and benefit but more importantly, for your customer's safety and benefit."

Door and gate system installers in Canada can access the complete ANSI/CAN/UL 325: 2020 Standard online at [www.ul.com](http://www.ul.com). For expert insights shared by our panel, view the webinar recording on the Miller Edge YouTube channel.

WATCH THE  
WEBINAR  
ON-DEMAND

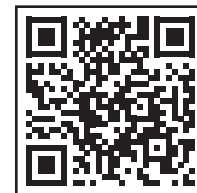

## PRODUCT SPOTLIGHT

### A Residential Parking Curb with a Promotional Advantage

## ParkDoc™

ParkDoc is a residential parking curb that allows a homeowner to find their prescribed parking spot.

Unlike other parking aids, ParkDoc also gives an installer the opportunity to market their garage door business by customizing ParkDoc with their company's information, keeping their business front of mind for homeowners.

ParkDoc can be utilized to increase homeowner parking safety and increase brand awareness; a win-win for your customer and you.

With a customized label featuring your company, ParkDoc can be used to boost business recognition:

- Promotional gift. Send to new customers as a "thank you" for their business.
- Friendly service reminder. Give to customers to remind them to make an appointment to service their garage doors.
- Retail sales. Offer to walk-in customers or take it with you on the road as a unique product offering.

Contact your Sales Rep to customize ParkDoc today.



## Automated Bifold Vehicular Gates

Defined in ANSI/CAN/UL 325: 2023 Safety Standard

On February 21, 2023, revisions to ANSI/CAN/UL 325 included clarification to entrapment zones located on vehicular bifold gates. Per the UL 325 safety standard, entrapment protection must be present on: “Locations between a moving bifold gate or moving, exposed operator components and a counter opposing edge or surface where entrapment is possible up to 1.8 m (6-ft.) above grade.”

It is the installer’s responsibility to determine the number of potential areas where the risk of entrapment may exist.

As your resource in universal gate safety, shown here are potential mounting locations for Miller Edge safeguarding solutions on a bifold gate. Illustrations show common product placement locations to consider; however, each installation is unique. Be sure to consider all potential safety hazards and incorporate appropriate Miller Edge guarding into your overall gate design.

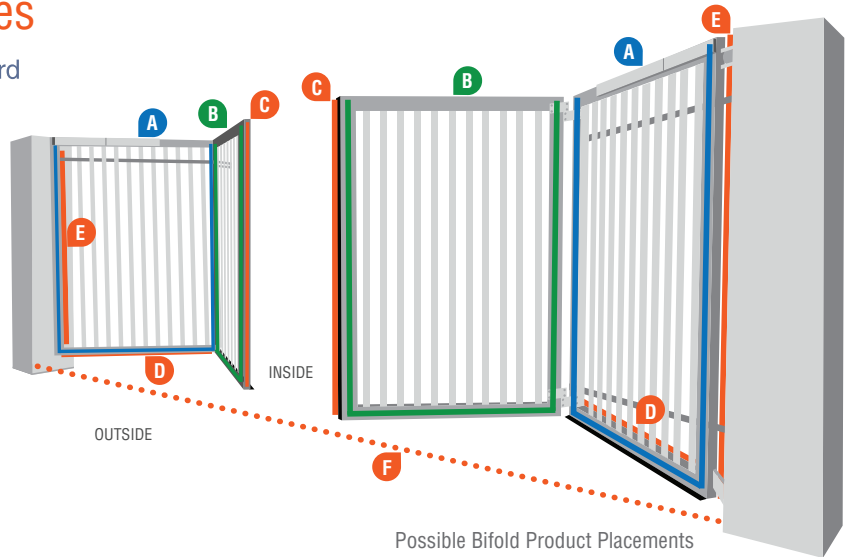

### MOUNTING LOCATIONS

- A. Outer column panel ‡
- B. Inner bifold panel ‡
- C. Leading edge/Inner bifold panel ‡
- D. Outer column panel, outside horizontal bottom edge
- E. Post/column/pillar
- F. Driveway

### SUGGESTED PRODUCTS

- A. MG110, CPT210, ME120, MG123\*
- B. MG110, CPT210, ME120, MG123\*
- C. MG110, CPT210, ME120, MG123, MGR20, MGS20
- D. ME120 (+ ME120-C5), MGR20, MGS20
- E. MG110, CPT210
- F. TruGuard™, OptiGuard™

\* Edges can be ordered series connected.

‡ Per the UL 325 safety standard, only one panel/leading edge requires protection, second is optional.

**For more information**, read your gate operator’s manual and follow the manufacturer’s requirements. Detailed information about bifold gate system safety is provided by UL Solutions ([www.ul.com](http://www.ul.com)) and DASMA ([www.dasma.com](http://www.dasma.com)).

## NEW PRODUCTS



## New! Photo Eye Conduit Enclosure Kit

Compatible with TruGuard™ (TG-R-K10) and OptiGuard™ (OG-T-K10)

The Photo Eye Conduit Enclosure Kit (PE-CON-K10) pairs seamlessly with TruGuard™ (TG-R-K10) and OptiGuard™ (OG-T-K10) photo optic systems by Miller Edge. The integrated ¾” Type-C conduit body provides a protective pathway for wires in installations using conduit while ensuring a clear connection to operator controls. This accessory features a hood designed to provide added shielding to the photo eye from sunlight, moisture, dust, and debris. With a swivel bracket for easy alignment, the Photo Eye Conduit Enclosure Kit ensures optimal positioning of an accompanying photo eye or reflector.

## US West Region

New Regional Sales Manager

Brian Vainisi joined Miller Edge as Western Regional Sales Manager in July. Brian has over a decade of sales and operations experience, graduating with a BS in Business Administration and Marketing from the University of Phoenix in Arizona. He has held notable roles in product training, account management, and project consulting while building strong relationships with general contractors, manufacturers, architects, and end users. Brian will work closely with customers in the US West Region to provide support, grow, and expand their business.



**BRIAN VAINISI**  
**Regional Sales Manager**  
bvainisi@milleredge.com  
800-220-3343 x315



**LISA LEATHER**  
**Inside Sales Rep.**  
lleather@milleredge.com  
800-220-3343 x214



Powered by MillerEdge  
**MyEdge**  
myedge.milleredge.com

**24/7 Ordering & Account Access**

**Manage Your Miller Edge Business**

**Easy Access to Sales Tools & Resources**

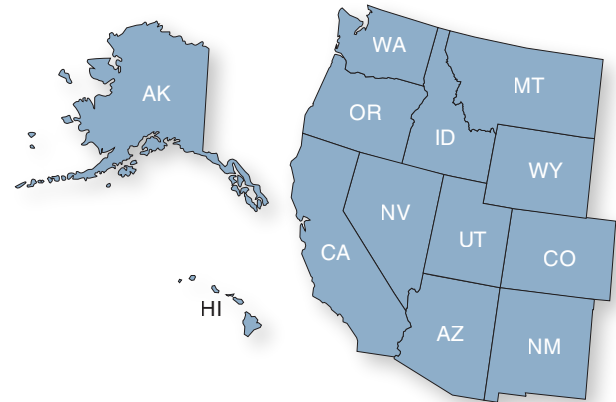

US West Region

## EVENTS

### Tradeshows

National & Regional Events

**August 23-25:**

**The Fence Show & Security Expo**  
Booth #509  
Las Vegas, NV

**September 28-29:**

**WASA 2023 Trade Show**  
Booth #39  
Las Vegas, NV

**October 17-20:**

**Fall IDA EduCon & Trade Show**  
Booth #305  
Milwaukee, WI

### Door Safety Education

An 8-Part Series in Partnership with Service Spring Corporation

**August 8:**

**Selling Safety for Commercial Overhead Doors**  
*Featuring the New Levels of Protection Guide*  
Service Spring Corp. Indianapolis Service Center

**August 11:**

**Introduction to Photo Optics: Which Style is Best for You?**  
*Exploring the Features & Benefits of Single and Multi-Beam Photo Eyes*  
Service Spring Corp. Baltimore Service Center

**August 24:**

**Introduction to Sensing Edges: Functionality & Operation**  
*What They Are, How They Work, and Key Concepts Explained*  
Service Spring Corp. Detroit Service Center

### Safeguarding Building Designs

From offering continuing education courses to architects to providing architect access to Miller Edge safeguarding solutions through the ARCAT specification database, we engage with architects in various capacities to drive door and gate awareness. For example, architects can access 2D CAD drawings, which serve as the foundation for project contracts, via CADdetails to specify sensing edges and photo eyes for commercial motorized doors and automated vehicular gates. These drawings effectively convey essential project details, ensuring the implementation of compliant doors and gates for safe building designs. As a building product manufacturer, ensuring the accessibility of our products is pivotal to simplify their specification within construction project plans.

On the Miller Edge CADdetails profile, architects can access product specifications, view product listings on various door and gate styles, and download technical drawings. Each CAD drawing is available to download for free in multiple file formats, making it easy to locate and specify required safeguarding solutions. These drawings include technical details and elevation drawings, providing architects with the ability to choose the right safety product for the type of door or gate they are specifying.

Additional resources found on our profile include informational brochures and case studies highlighting our products in real-world applications, making it convenient for architectural professionals to find all the information needed for their building designs. Explore our profile on CADdetails.com to discover these valuable architectural resources.

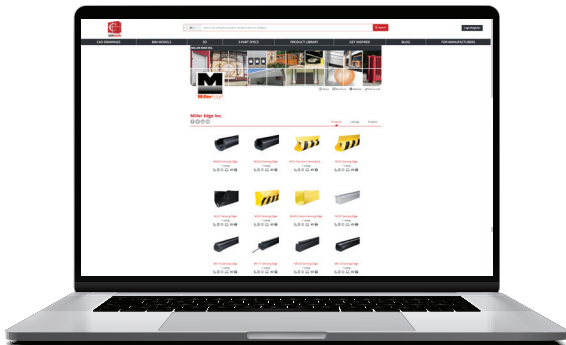

### Case Study: Monitored Light Curtains

In Partnership with



Miller Edge partnered with Overhead Door Company of Lexington to find the optimal photo optic sensor to improve traffic flow and reduce damage to fire trucks at the Winchester Fire Department in Winchester, Kentucky. The fire station, equipped with six overhead sectional doors, ran into detection issues with the previously installed photo eyes mounted at six-inches from the ground. Because fire trucks fluctuate in height based on how much water they carry, fire apparatus may not come into contact with a single light beam, which previously caused unwanted contact between apparatus and station doors.



To best detect all parts of the fire apparatus and to keep the vehicles, facility, and personnel safe, Overhead Door Company of Lexington installed three-foot Miller Edge Monitored Light Curtains (MLC-K36) on six doors. The light curtains provide monitored protection with greater vertical coverage

allowing the installed devices to recognize vehicles regardless of height, eliminating service calls for this location and frustrations for the facility manager.

Travis Moore from Overhead Door Company of Lexington shares, "the Winchester Fire Department reports the Monitored Light Curtains are operating exceptionally at their station. Our company recommends Miller Edge light curtains over competitor products due to the quality of their performance."

READ THE  
FULL CASE  
STUDY





**OptiGuard™**  
Thru-Beam Photo Eye

**We brought our  
A-TEAM**



**TruGuard™**  
Reflective Photo Eye

**MillerEdge®**

PO Box 159  
West Grove, PA 19390 USA

-  800-220-3343
-  [info@milleredge.com](mailto:info@milleredge.com)
-  [www.milleredge.com](http://www.milleredge.com)
-  [myedge.milleredge.com](http://myedge.milleredge.com)

-  @miller-edge-inc
-  @MillerEdge
-  @MillerEdge
-  @milleredgeinc
-  @MillerEdgeInc

**SUBSCRIBE**

Want to stay in the know? Sign up to receive email announcements at [www.milleredge.com](http://www.milleredge.com) today! Just click [Join Our Mailing List](#).



TALK TO THE TECH

**Frequently Asked Questions**

By Walt, Miller Edge Technical Support Expert

 **TECHTIP**



**Coil Cords vs. Retracting Reels**

Sensing Edge Wiring Methods for Commercial Overhead Doors



Using the correct components and tools on the job is always important when installing safety devices. Were you aware that a sensing edge's wiring method should be selected based on whether a system is monitored or non-monitored? When deciding between a coil cord and a retracting reel, use the following:

**Wired Connections: Sensing Edge to Operator Controls**

-  **Monitored systems** Use a **coil cord**
-  **Non-monitored systems** Use a **coil cord** or a **retracting reel**

Alternatively, in environments calling for **wireless connections**, use RBand for Doors (RB-P-K10C) for monitored systems and a non-monitored transmitter/receiver such as our MWRT12 or MWRTA12 for non-monitored systems.

**Identifying Edge Configurations**

Unsure of the configuration of a sensing edge? An Edge Tester (MET-101) will identify the termination of any Miller Edge sensing edge for operator compatibility or help troubleshoot faults within a system.

To determine the edge configuration required by an operator, refer to your operator manual.

**Questions?**

For more information or to speak with Technical Support, send an email to [techsupport@milleredge.com](mailto:techsupport@milleredge.com) or call 800-220-3343 and select option 2.

The options illustrated comply with building codes in the USA and Canada. Select the protection that best suits the needs of your environment.

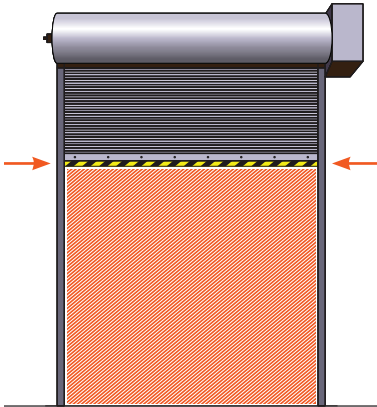

### SENSING EDGE

#### Activation Method



Contact

#### Vertical Coverage



Full

#### Obstruction Detection



Excellent

#### Price Range



Moderate

#### Advantages

- Wireless option reduces additional cords around the door
- Can be combined with photo optics for added non-contact protection
- Ideal for standard speed doors and all cycle types (low, medium, high)
- Most vertical coverage; door to floor protection full path of travel
- Compact/unobtrusive

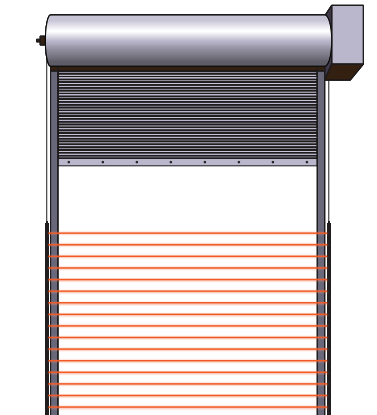

### MULTI-BEAM PHOTO OPTIC

6-ft. Light Curtain

#### Activation Method



Non-Contact

#### Vertical Coverage



High

#### Obstruction Detection



Excellent

#### Price Range



Highest

#### Advantages

- Largest non-contact protection field decreases damage and injury
- Ideal for standard and high speed and all cycle type doors (low, medium, high)
- Can be combined with a sensing edge for added protection
- Compact/unobtrusive

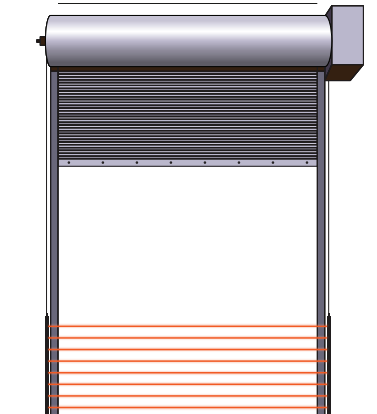

### MULTI-BEAM PHOTO OPTIC

3-ft. Light Curtain

#### Activation Method



Non-Contact

#### Vertical Coverage



Medium

#### Obstruction Detection



Good

#### Price Range



Moderate

#### Advantages

- Medium non-contact protection field decreases damage and injury
- Ideal for standard and high speed and all cycle type doors (low, medium, high)
- Can be combined with a sensing edge for added protection
- Compact/unobtrusive

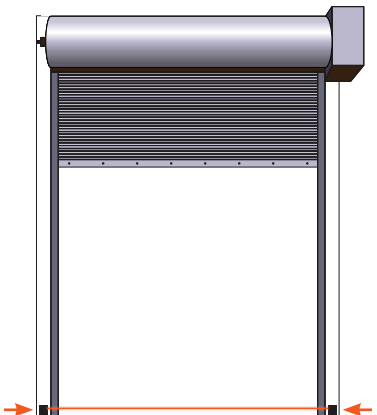

### SINGLE-BEAM PHOTO OPTIC

Thru-Beam & Reflective

#### Activation Method



Non-Contact

#### Vertical Coverage



Low

#### Obstruction Detection



Meets Requirement

#### Price Range



Lowest

#### Advantages

- Lowest upfront cost
- No contact required to detect obstruction
- Ideal for standard speed and low cycle doors
- Compact/unobtrusive



### RECOGNIZING THE NEED FOR PROTECTION

The door illustrations shown in this guide demonstrate protection to consider when safeguarding motorized commercial overhead doors; however, each environment is unique.

When selecting the appropriate level of protection for a motorized overhead door, be sure to consider all potential safety hazards and incorporate the appropriate Miller Edge safeguarding into your overall door installation.



### HAZARD & RISK AWARENESS

For basic hazard and risk awareness around commercial doors, look at the environment and consider what needs to be protected:

- Personnel injury or death hazard
- Risk of damage to incoming raw materials
- Risk of damage to outgoing finished goods
- Risk of damage to vehicles, equipment, and property



### ASSOCIATED COSTS

What are the costs that could result from a door that is damaged and non-operational?

- Door replacement
- Loss of use
- Loss of customer goodwill
- Business delays
- Lost productivity



### OTHER CONSIDERATIONS

Consider all entrapment and productivity hazards and risks to property when determining suitable protection:

- Personal injury or death hazard
- Risk of material, product, equipment, or property damage
- Intended use and location of door—what is passing through the door opening?
- Business impact due to loss of ability to use door